

REV. LETTER	D'WN BY	CHK BY	DATE	CHANGES
-	-	-	-	-
-	-	-	-	-

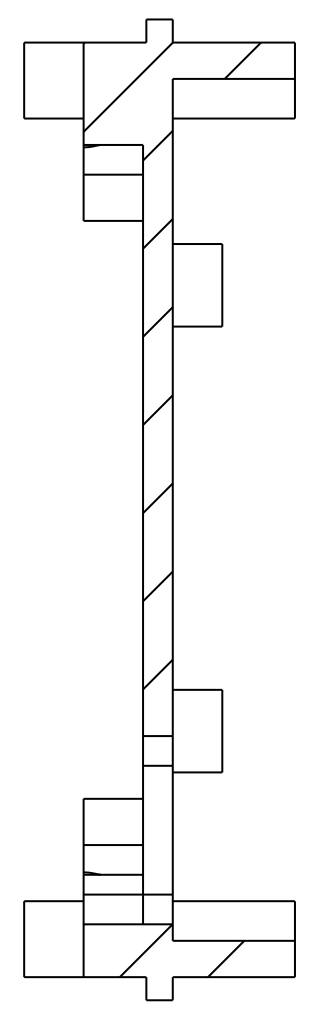

SECTION A-A

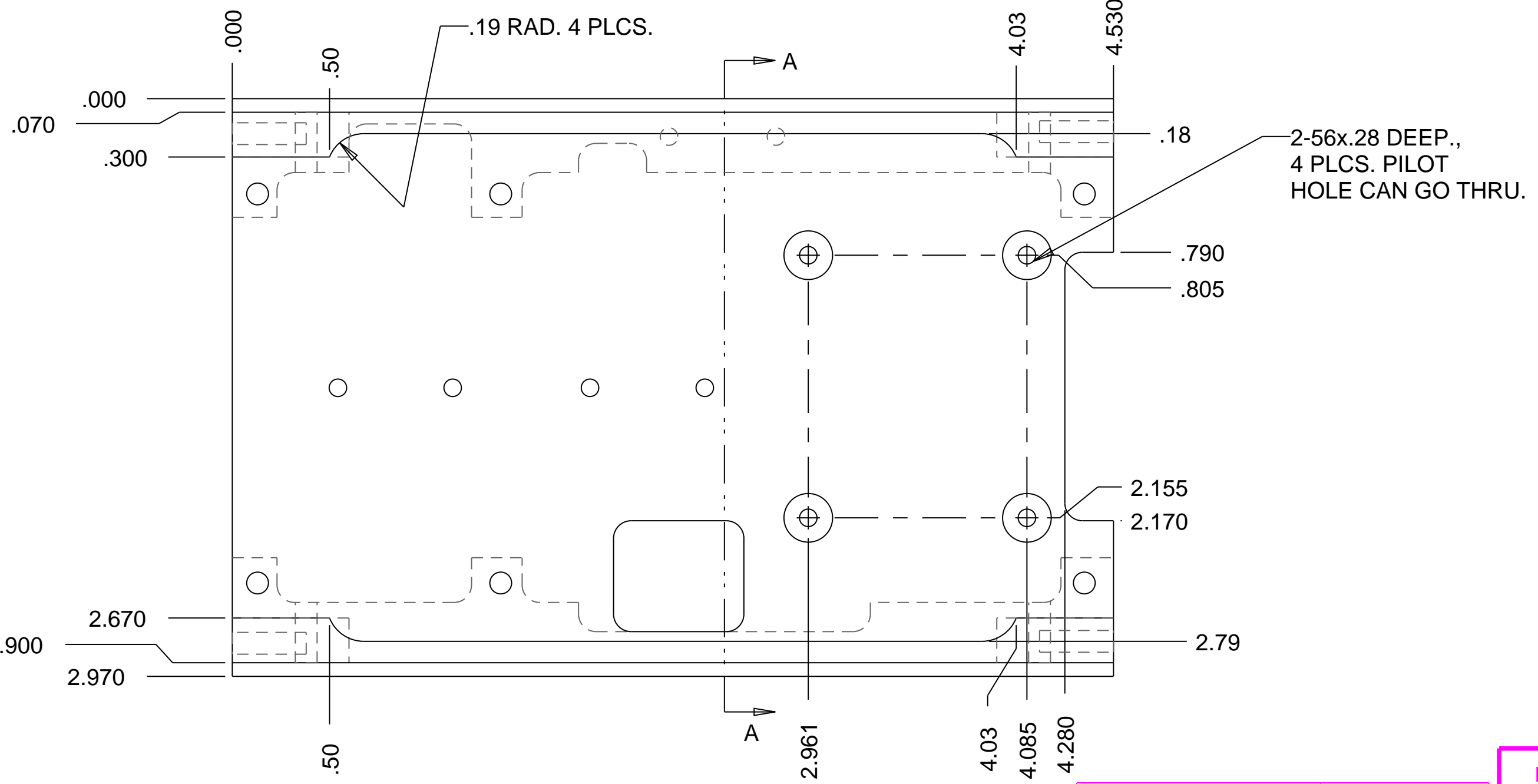
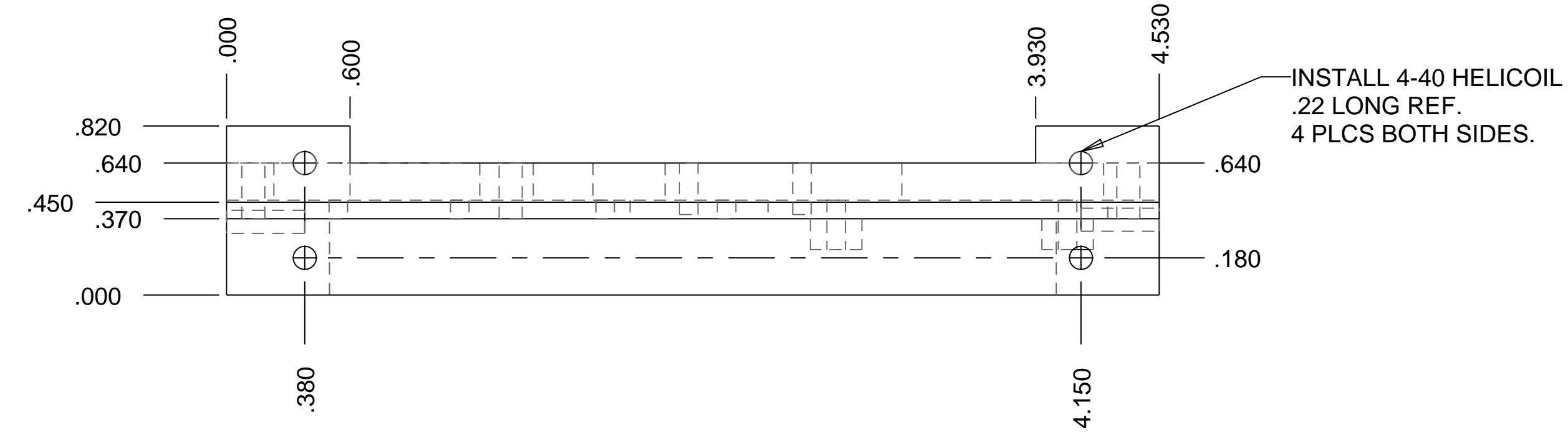
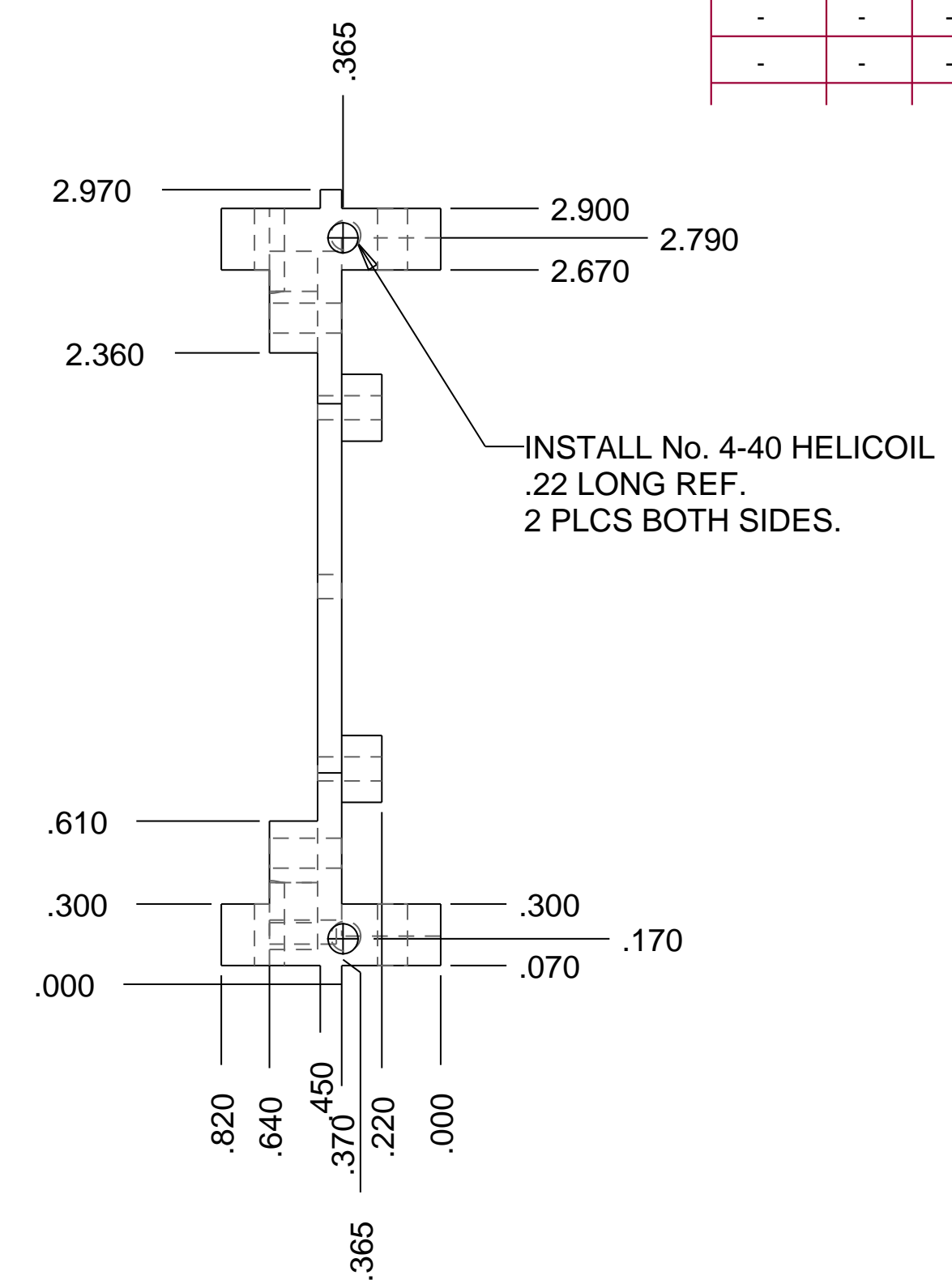
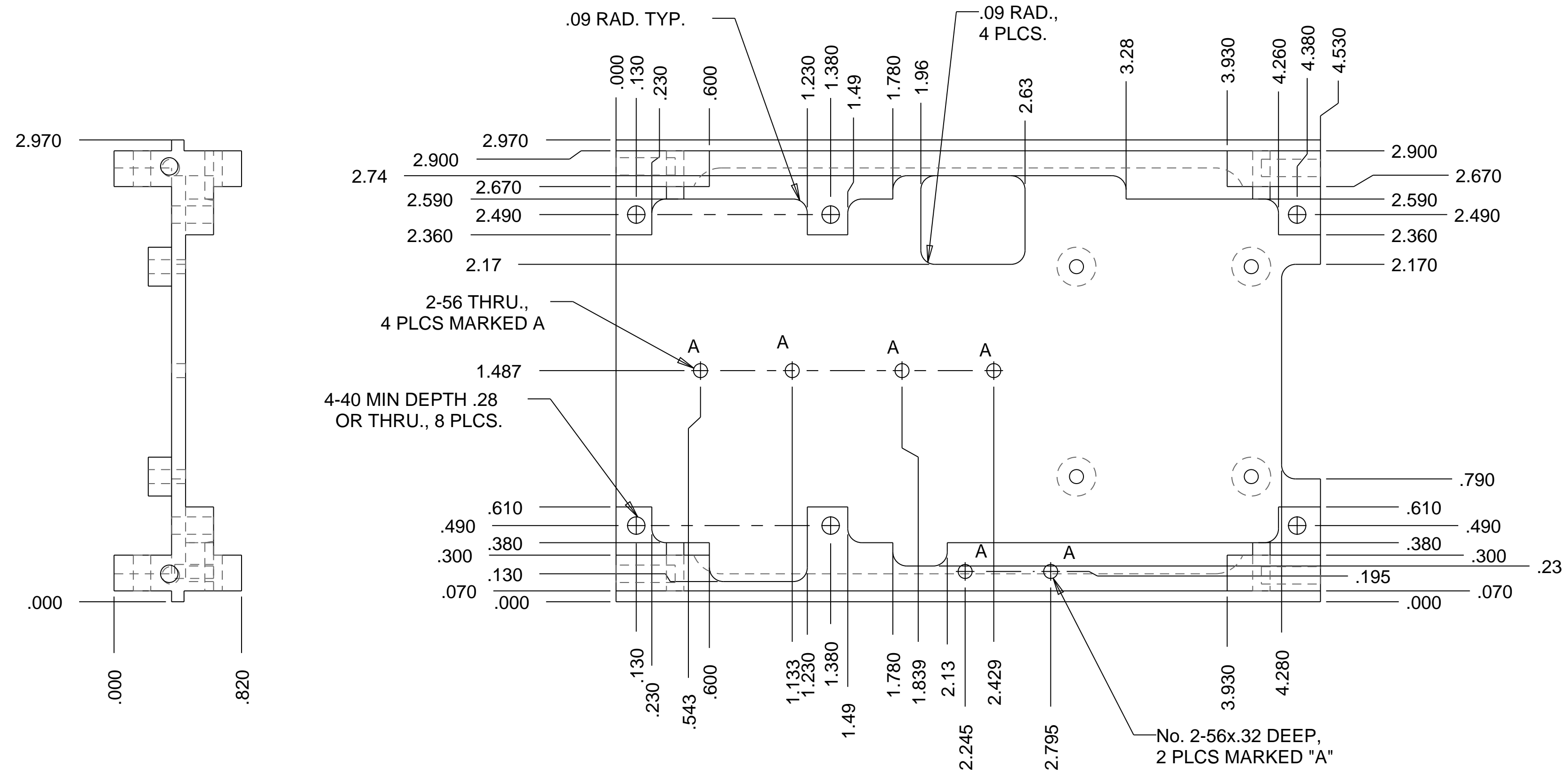
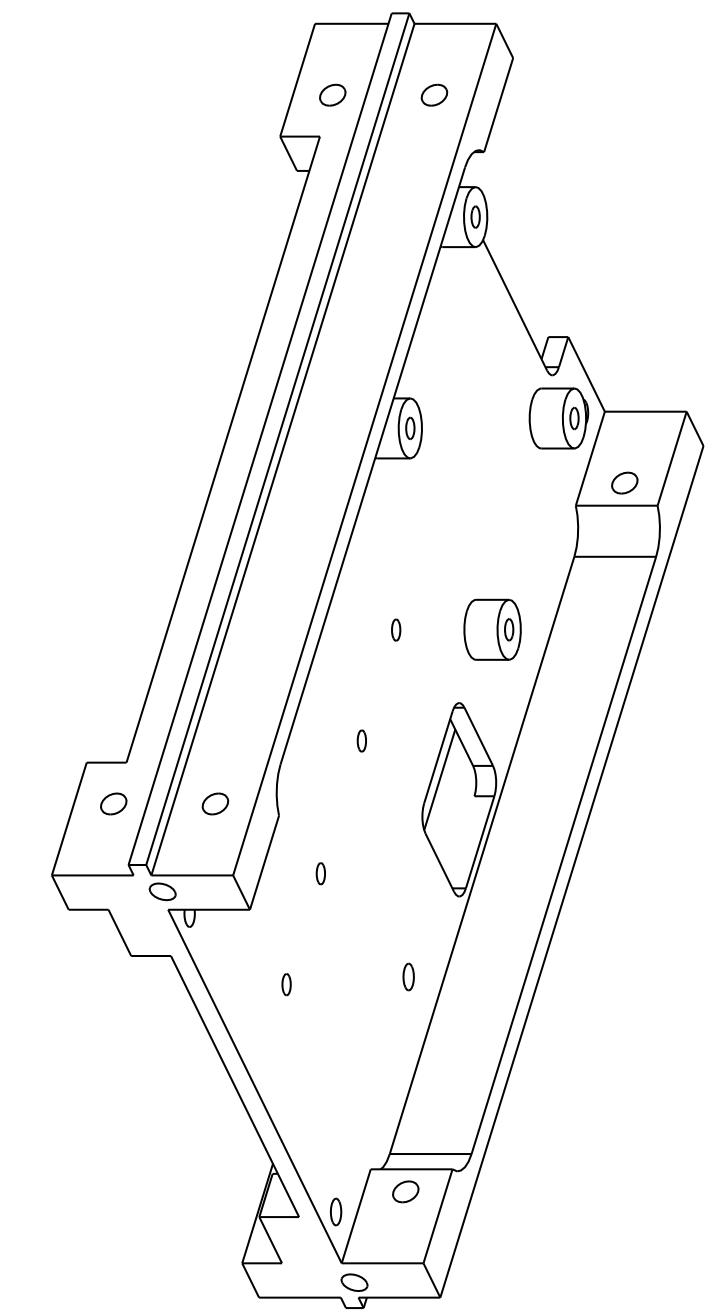

SCALE 1.250

- NOTES:
1. MATERIAL: ALUMINUM 6061-T6.
 2. PAINT TBD COLOR AND AREA.

MACH. PROG. No.
MACH. PROG. No.
MACH. PROG. No.
FOR MITRE PROTOTYPE FABRICATION ONLY. DRAWINGS NOT COMPLETE FOR OUTSIDE FABRICATION

GROUP QTY	FIND NO.	DESCRIPTION	PART NO.	MATERIAL	MFR/CODE
4	1	DESIGN TEAM			MITRE
UNLESS OTHERWISE SPECIFIED DIMENSIONS ARE IN INCHES		DRAFTER	E53D PROTOTYPE DEVELOPMENT DEPARTMENT		
TOLERANCES ON DECIMALS ANGLES		CHECKER	202 BURLINGTON ROAD		
.XX ± .01 ± 1/2 °		REQUESTER	BEDFORD MA 01730		
.XXX ± .005 ± -		RELEASE	(617) 271-2000		
FINISH:		DEPT.	TITLE		
PAINT:		JOB NO.	SPINE HOLDER		
SILK-SCREEN:		PROJECT	UAT ENCLOSURE		
NEXT ASSEMBLY		CODE IDENT. NUMBER	SIZE	DRAWING NUMBER	
		4B080	D	200-2146-01 REV. X1	
		DO NOT SCALE	SCALE:	LBS:	Sheet of -